

pressure limitation valve

type SPB-H 15

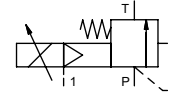

control valve proportional
pressure range PN 5-120 bar
orifice DN 15 mm
connection thread
function stepless pressure regulation bypass version



Above stated body materials refer to the valve port connections that get in contact with the media only!

design externally controlled with spring return
body materials ① ④
 ② steel, galvanized ⑤
 ③ ⑥
valve seat metal on metal
seal materials FPM, PTFE

details needed for main valve

- orifice
- port
- pressure regulating range
- flow rate
- media
- media temperature
- ambient temperature

details needed for proportional valve

- nominal voltage
- actuation pressure range min/max

general specifications

ports	SPB	threads G 1	options	SAE connection DIN ISO 6162
function		stepless regulation		
pressure regulation range	bar	5-120		
Kv value	m ³ /h	6,0		
media		liquid - highly viscous - contaminated		
abrasive media				
flow direction	P ⇌ T	as marked		
operating time	ms	< 900		
media temperature	°C	0 to +60		
ambient temperature	°C	0 to +50		
approvals				
mounting		mounting holes		
weight	kg	2,7		
additional equipment				actuation pressure gauge

electrical specifications

nominal voltage	U _B	DC 24 V (max. residual ripple 10%)	options	
power consumption	DC	< 0,7 A		
control signals	U _E	0-10 V (R _e 100KΩ)		
protection	IP65	acc. DIN 40 050		
energized duty rating	ED	100% (observe the connection conditions accordingly)		
connection		plug with 7 contacts / wire diameter 6-8 mm		

pneumatic specifications

actuation pressure range	bar	see actuation pressure-diagram	options	
air consumption		DIN ISO 8573-1 grade of compressed air quality 5/4/3		
control		by 3/2-way proportional valve		
actuator ports	1	G 1/8		

The valves' technical design is based on media and application requirements. This can lead to deviations from the general specifications shown on the data sheet with regards to the design, sealing materials and characteristics.

If order or application specifications are incomplete or imprecise there exists a risk of an incorrect technical design of the valve for the required application. As a consequence, the physical and / or chemical properties of the materials or seals used, may not be suitable for the intended application.

connection plan

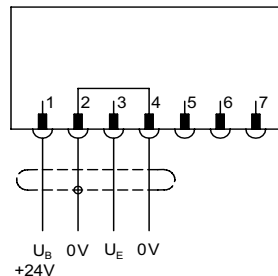

connection conditions

When supplying the electrical set point signal to the proportional valve, the actuating air must already be present. (see actuation pressure-diagram)

position of installation

arbitrarily, but regulator not downwards

■ specifications not highlighted are standard
 ■ specifications highlighted in grey are optional

type SPB-H 15

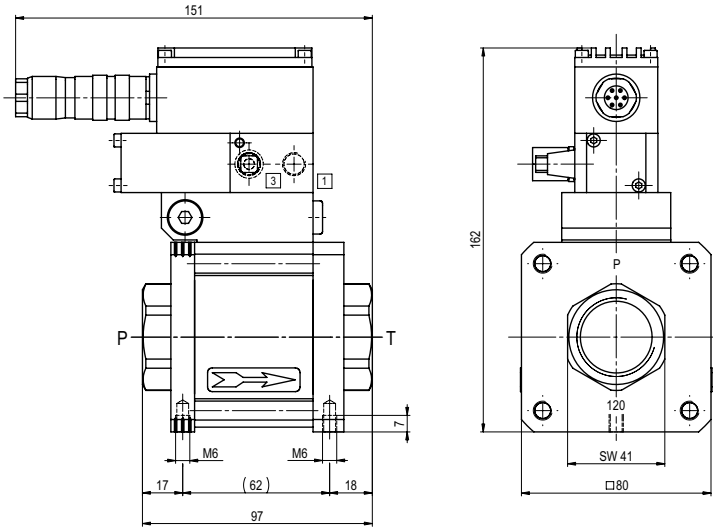

actuation pressure-diagram

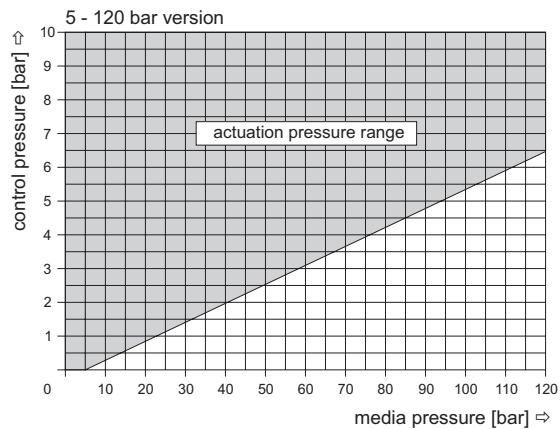

pressureless circulation mode

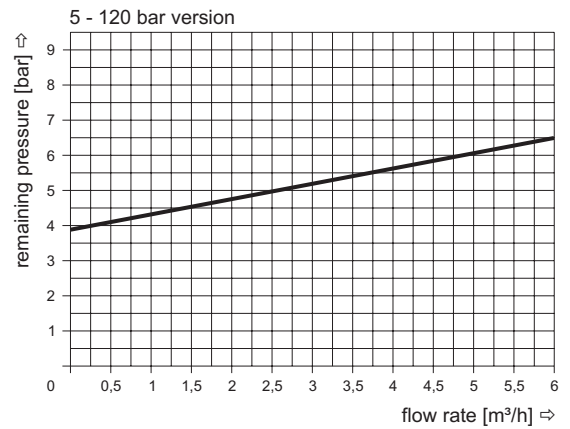

Sound creation during low pressure circulation mode and flow $Q=6 \text{ m}^3/\text{h}$: ca. 70 dbA