

coaxial valve

type MK 50 DR Ex FK 50 DR Ex

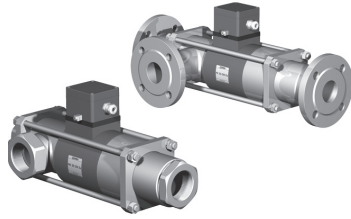

3/2 way valve **direct acting**
pressure range PN 0-16 bar
orifice DN 50 mm
connection thread/flange
function valve normally closed (A ► B) symbol **NC**
 valve normally open (A ► B) symbol **NO**

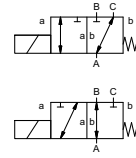

△ Above stated body materials refer to the valve port connections that get in contact with the media only!

design pressure balanced, with spring return, intersecting switch-over
body materials ① ② steel, galvanized
 ③ ⑤ without non-ferr. metals
 ④ steel, nickel plated ⑥ stainless steel
valve seat synthetic resin on metal
seal materials NBR PTFE, FPM, CR, EPDM

details needed

- orifice
- port
- function NC/NO
- operating pressure
- inlet pressure at A, B or C
- flow rate
- media
- media temperature
- ambient temperature
- nominal voltage

general specifications		options
ports	MK threads G 2 FK flanges PN 16	special threads special flanges
function	NC	NO
pressure range	bar 0-16	
	A ⇒ B max.16 / B ⇒ A max.10 / A ⇒ C max.16 / C ⇒ A max.16	
Kv value	m ³ /h 28,2	
vacuum	leak rate	< 10 ⁻⁶ mbar·l·s ⁻¹
pressure-vacuum	P ₁ ⇔ P ₂	upon request
back pressure	P ₂ > P ₁ see pressure range	
media	gaseous - liquid - highly viscous - gelatinous - contaminated	upon request
abrasive media		upon request
damping	opening closing	
flow direction	see pressure range	
switching cycles	1/min 40	
switching time	ms opening 400 closing 400	
media temperature	°C DC: -20 to +40 AC: -20 to +40	
ambient temperature	°C DC: -20 to +40 AC: -20 to +40	
limit switches		inductive
manual override		available
approvals		LR/GL/WAZ
mounting		mounting brackets
weight	kg MK 31,5 FK 38,5	
additional equipment		upon request

⚠ The valves' technical design is based on media and application requirements. This can lead to deviations from the general specifications shown on the data sheet with regards to the design, sealing materials and characteristics.

⚠ If order or application specifications are incomplete or imprecise there exists a risk of an incorrect technical design of the valve for the required application. As a consequence, the physical and / or chemical properties of the materials or seals used, may not be suitable for the intended application.

electrical specifications		options
nominal voltage	U _n 24 V DC	special voltage
	U _n 230 V 40-60 Hz AC	special voltage
actuation	DC direct-current magnet	
	AC direct-current magnet with separate rectifier outside of the explosion-proof area	sand sealed rectifier
insulation rating	H 180°C	
protection	IP65	
energized duty rating	ED 100%	
connection	M16x1,5 terminal box	
optional additional equipment		
current consumption	U _n V-DC 24 210	48 98 110 220
	I _n A 2,80 0,33	1,48 0,72 0,57 0,32
explosion proof	II 2 G Eex me II T4 and II 2 D IP65 T 130°C PTB 03 ATEX 2056 X	
limit switches	inductive NAMUR	circuit amplifier

■ specifications not highlighted are standard
 ■ specifications highlighted in grey are optional

type MK 50 DR Ex

function: **NC**
closed when not energized (A ► B)

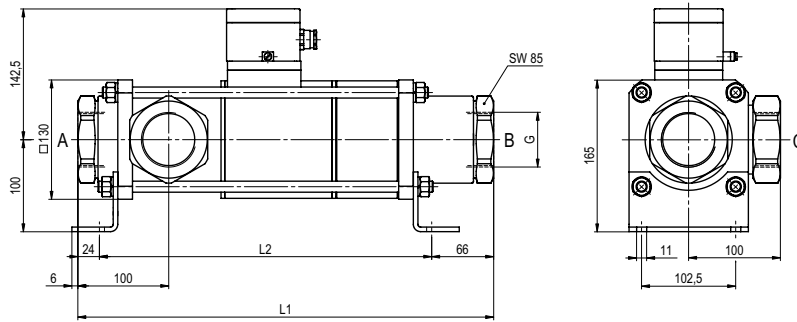

constructive length	L ₁	L ₂	L ₃
standard	453	363	553
with 1/2 inductive limit switches	453	363	553
with manual emergency (Hd)/ Hd and 1/2 ind. limit switches	453	363	553

flanges PN	DIN	øD	øk	ød
16	2633	165	125	18

type FK 50 DR Ex

function: **NO**
open when not energized (A ► B)

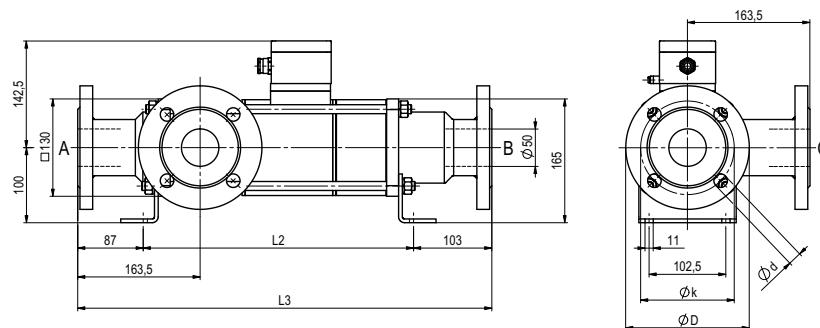

The application-specific layout relating to temperature, pressure conditions, switching behavior, media and its consistency may restrict the range of use or necessitate relevant modifications to materials used and seal arrangements.

Rights reserved to make technical alterations • Not responsible for printing errors • Detailed drawings can be obtained upon request