

coaxial valve

type MK 32 DR FK 32 DR

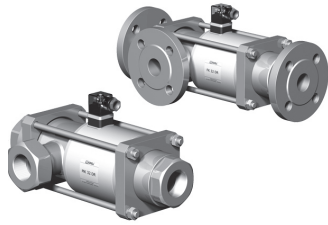

3/2 way valve **direct acting**
pressure range PN 0-40 bar
orifice DN 32 mm
connection thread/flange
function valve normally closed (A ► B) symbol **NC**
 valve normally open (A ► B) symbol **NO**

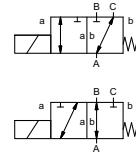

△ Above stated body materials refer to the valve port connections that get in contact with the media only!

design pressure balanced, with spring return, intersecting switch-over
body materials ① ② steel, galvanized
 ③ ⑤ without non-ferr. metals
 ④ steel, nickel plated ⑥ stainless steel
valve seat synthetic resin on metal
seal materials NBR PTFE, FPM, CR, EPDM

details needed

- orifice
- port
- function NC/NO
- operating pressure
- inlet pressure at A, B or C
- flow rate
- media
- media temperature
- ambient temperature
- nominal voltage

	general specifications	options
ports	MK threads G 1 1/4 - G 1 1/2 FK flanges PN 16/40	special threads special flanges
function	NC	NO
pressure range	bar 0-16/0-40 A ⇒ B max.40 / B ⇒ A max.16 / A ⇒ C max.40 / C ⇒ A max.16	
Kv value	m ³ /h 14,1 [A ⇒ B] 8,9 [A ⇒ C]	
vacuum	leak rate < 10 ⁻⁶ mbar·l/s ⁻¹	
pressure-vacuum	P ₁ ⇔ P ₂ upon request	
back pressure	P ₂ > P ₁ see pressure range	
media	gaseous - liquid - highly viscous - gelatinous - contaminated	upon request
abrasive media		upon request
damping	opening closing	
flow direction	see pressure range	
switching cycles	1/min 120	
switching time	ms opening 440 closing 250	
media temperature	°C DC: -20 to +100 AC: -20 to +100	-40 to +160 -40 to +160
ambient temperature	°C DC: -20 to +80 AC: -20 to +80	
limit switches		inductive/mech. (depend. on temperature)
manual override		available
approvals		LR/GL/WAZ
mounting		mounting brackets
weight	kg MK 18,0 FK 22,0	
additional equipment		upon request

⚠ The valves' technical design is based on media and application requirements. This can lead to deviations from the general specifications shown on the data sheet with regards to the design, sealing materials and characteristics.

⚠ If order or application specifications are incomplete or imprecise there exists a risk of an incorrect technical design of the valve for the required application. As a consequence, the physical and / or chemical properties of the materials or seals used, may not be suitable for the intended application.

	electrical specifications	options
nominal voltage	U _n 24 V DC U _n 230 V 40-60 Hz AC	special voltage upon request special voltage upon request
actuation	DC direct-current magnet AC direct-current magnet with integrated rectifier	above 100°C with separate rectifier
insulation rating	H 180°C	
protection	IP65	
energized duty rating	ED 100%	
connection	plug acc. DIN EN 175301-803 form A, 4 positions x 90° / wire diameter 6-8 mm	terminal box M16x1,5
optional additional equipment	illuminated plug with varistor	
current consumption	N-coil 24 V DC 2,07 A 230 V 40-60 Hz AC 0,28 A H-coil 24 V DC 3,27 A 230 V 40-60 Hz AC 0,44 A	
explosion proof		
limit switches	inductive (I) normally open-PNP inductive (B) normally open-PNP mechanical single pole double throw-SPDT	

■ specifications not highlighted are standard
 ■ specifications highlighted in grey are optional

type MK 32 DR

function: **NC**
closed when not energized (A ► B)

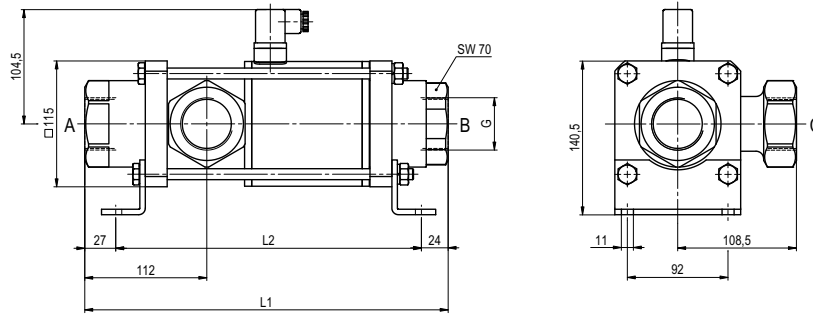

constructive length	L ₁	L ₂	L ₃
standard	332	281	394
with 1/2 inductive limit switches	373	322	435
with manual emergency (Hd)/ Hd and 1/2 ind. limit switches	373	322	435
with mechanical limit switches	373	322	435

flanges PN	DIN	øD	øk	ød
16	2633	140	100	18
40	2635	140	100	18

type FK 32 DR

function: **NO**
open when not energized (A ► B)

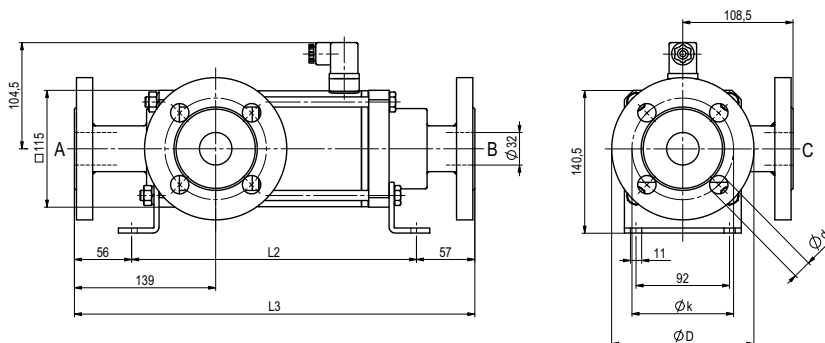

The application-specific layout relating to temperature, pressure conditions, switching behavior, media and its consistency may restrict the range of use or necessitate relevant modifications to materials used and seal arrangements.

Rights reserved to make technical alterations • Not responsible for printing errors • Detailed drawings can be obtained upon request