

# coaxial valve

type **MK 32**  
**FK 32**

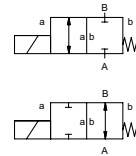

**2/2 way valve** **direct acting**  
**pressure range** PN 0-100 bar  
**orifice** DN 32 mm  
**connection** thread/flange  
**function** valve normally closed symbol **NC**  
 valve normally open symbol **NO**



**△** Above stated body materials refer to the valve port connections that get in contact with the media only!

**design** pressure balanced, with spring return  
**body materials** ① brass ② steel, galvanized  
 ③ brass, nickel plated ⑤ without non-ferr. metals  
 ④ steel, nickel plated ⑥ stainless steel  
**valve seat** synthetic resin on metal  
**seal materials** NBR PTFE, FPM, CR, EPDM

**details needed**

- orifice
- port
- function NC/NO
- operating pressure
- flow rate
- media
- media temperature
- ambient temperature
- nominal voltage

general specifications		options
<b>ports</b>	MK threads G 1 1/4 - G 1 1/2 FK flanges PN 16/40/64/100	special threads special flanges
<b>function</b>	NC	NO
<b>pressure range</b>	bar 0-16/0-40/0-64/0-100	
<b>Kv value</b>	m³/h 14,1	
<b>vacuum</b>	leak rate < 10 <sup>-6</sup> mbar·l·s <sup>-1</sup>	
<b>pressure-vacuum</b>	P <sub>1</sub> ↔ P <sub>2</sub> upon request	
<b>back pressure</b>	P <sub>2</sub> > P <sub>1</sub> available (max. 16 bar)	
<b>media</b>	gaseous - liquid - highly viscous - gelatinous - contaminated	
<b>abrasive media</b>		upon request
<b>damping</b>	opening closing	available
<b>flow direction</b>	A ↔ B as marked	bi-directional (max. 16 bar)
<b>switching cycles</b>	1/min 120	
<b>switching time</b>	ms opening 440 closing 250	
<b>media temperature</b>	°C DC: -40 to +100 AC: -40 to +100	-40 to +160 -40 to +160
<b>ambient temperature</b>	°C DC: -40 to +80 AC: -40 to +80	
<b>limit switches</b>		inductive/mech. (depend. on temperature)
<b>manual override</b>		available
<b>approvals</b>		LR/GL/WAZ
<b>mounting</b>		mounting brackets
<b>weight</b>	kg MK 13,5 FK 17,5	
<b>additional equipment</b>		upon request

**⚠** The valves' technical design is based on media and application requirements. This can lead to deviations from the general specifications shown on the data sheet with regards to the design, sealing materials and characteristics.

**⚠** If order or application specifications are incomplete or imprecise there exists a risk of an incorrect technical design of the valve for the required application. As a consequence, the physical and / or chemical properties of the materials or seals used, may not be suitable for the intended application.

electrical specifications		options
<b>nominal voltage</b>	U <sub>n</sub> 24 V DC U <sub>n</sub> 230 V 40-60 Hz AC	special voltage upon request special voltage upon request
<b>actuation</b>	DC direct-current magnet AC direct-current magnet with integrated rectifier	above 100°C with separate rectifier
<b>insulation rating</b>	H 180°C	
<b>protection</b>	IP65	
<b>energized duty rating</b>	ED 100%	
<b>connection</b>	plug acc. DIN EN 175301-803 form A, 4 positions x 90° / wire diameter 6-8 mm	terminal box M16x1,5
<b>optional additional equipment</b>	illuminated plug with varistor	
<b>current consumption</b>	N-coil 24 V DC 2,07 A 230 V 40-60 Hz AC 0,28 A	
	H-coil 24 V DC 3,27 A 230 V 40-60 Hz AC 0,44 A	
<b>explosion proof</b>		
<b>limit switches</b>	inductive (I) normally open-PNP inductive (B) normally open-PNP mechanical single pole double throw-SPDT	

■ specifications not highlighted are standard  
 ■ specifications highlighted in grey are optional

# type MK 32

function: **NC**  
closed when not energized

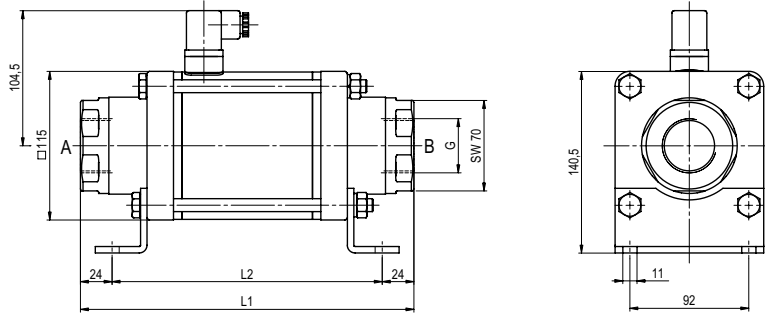

constructive length	L1	L2	L3
standard	258	210	324
with 1/2 inductive limit switches	299	251	365
with manual emergency (Hd)/ Hd and 1/2 ind. limit switches	299	251	365
with mechanical limit switches	299	251	365

flanges PN	DIN	øD	øk	ød
16	2633	140	100	18
40	2635	140	100	18
100	2637	155	110	22

# type FK 32

function: **NO**  
open when not energized

