

# coaxial valve

## type MK 25 DR Ex FK 25 DR Ex

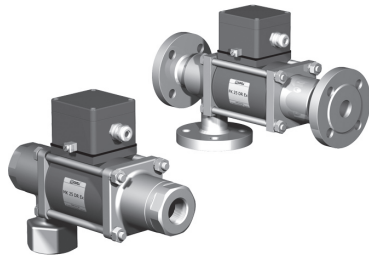

**3/2 way valve** **direct acting**  
**pressure range** PN 0-40 bar  
**orifice** DN 25 mm  
**connection** thread/flange  
**function** valve normally closed (A ► B)  
 symbol **NC**

valve normally open (A ► B)  
 symbol **NO**

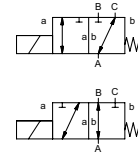

**△** Above stated body materials refer to the valve port connections that get in contact with the media only!

**design** pressure balanced, with spring return, intersecting switch-over  
**body materials** ① brass ② steel, galvanized  
 ③ brass, nickel plated ⑤ without non-ferr. metals  
 ④ steel, nickel plated ⑥ stainless steel

**valve seat** synthetic resin on metal  
**seal materials** NBR PTFE, FPM, CR, EPDM

**details needed**

- orifice
- port
- function NC/NO
- operating pressure
- inlet pressure at A, B or C
- flow rate
- media
- media temperature
- ambient temperature
- nominal voltage

general specifications		options
<b>ports</b>	MK threads G 1 - G 1 1/2 FK flanges PN 16/40	special threads special flanges
<b>function</b>	NC	NO
<b>pressure range</b>	bar 0-16/0-40 A ⇒ B max.40 / B ⇒ A max.16 / A ⇒ C max.40 / C ⇒ A max.16	
<b>Kv value</b>	m³/h 11,2	
<b>vacuum</b>	leak rate < 10 <sup>-6</sup> mbar·l·s <sup>-1</sup>	
<b>pressure-vacuum</b>	P <sub>1</sub> ⇔ P <sub>2</sub> upon request	
<b>back pressure</b>	P <sub>2</sub> > P <sub>1</sub> see pressure range	
<b>media</b>	gaseous - liquid - highly viscous - gelatinous - contaminated	upon request
<b>abrasive media</b>		upon request
<b>damping</b>	opening closing	
<b>flow direction</b>	see pressure range	
<b>switching cycles</b>	1/min 130	
<b>switching time</b>	ms opening 130 closing 130	
<b>media temperature</b>	°C DC: -20 to +40 AC: -20 to +40	-20 to +70 -20 to +70
<b>ambient temperature</b>	°C DC: -20 to +40 AC: -20 to +40	-20 to +70 -20 to +70
<b>limit switches</b>		inductive
<b>manual override</b>		LR/GL/WAZ
<b>approvals</b>		mounting brackets
<b>mounting</b>		
<b>weight</b>	kg MK 9,2 FK 12,0	
<b>additional equipment</b>		upon request

**⚠** The valves' technical design is based on media and application requirements. This can lead to deviations from the general specifications shown on the data sheet with regards to the design, sealing materials and characteristics.

**⚠** If order or application specifications are incomplete or imprecise there exists a risk of an incorrect technical design of the valve for the required application. As a consequence, the physical and / or chemical properties of the materials or seals used, may not be suitable for the intended application.

electrical specifications		options
<b>nominal voltage</b>	U <sub>n</sub> 24 V DC U <sub>n</sub> 230 V 40-60 Hz AC	special voltage special voltage
<b>actuation</b>	DC direct-current magnet AC direct-current magnet with separate rectifier outside of the explosion-proof area	sand sealed rectifier to +40°C max.
<b>insulation rating</b>	H 180°C	
<b>protection</b>	IP65	
<b>energized duty rating</b>	ED 100%	
<b>connection</b>	M16x1,5 terminal box	
<b>optional additional equipment</b>		
<b>current consumption</b>	U <sub>n</sub> V-DC 24 200 I <sub>n</sub> A 1,79 0,21	48 98 110 220 0,95 0,47 0,40 0,19
<b>explosion proof</b>	II 2 G Eex me II T4 and II 2 D IP65 T 130°C PTB 03 ATEX 2022 X	
<b>limit switches</b>	inductive NAMUR	circuit amplifier

■ specifications not highlighted are standard  
 ■ specifications highlighted in grey are optional

# type MK 25 DR Ex

function: **NC**  
closed when not energized (A ► B)

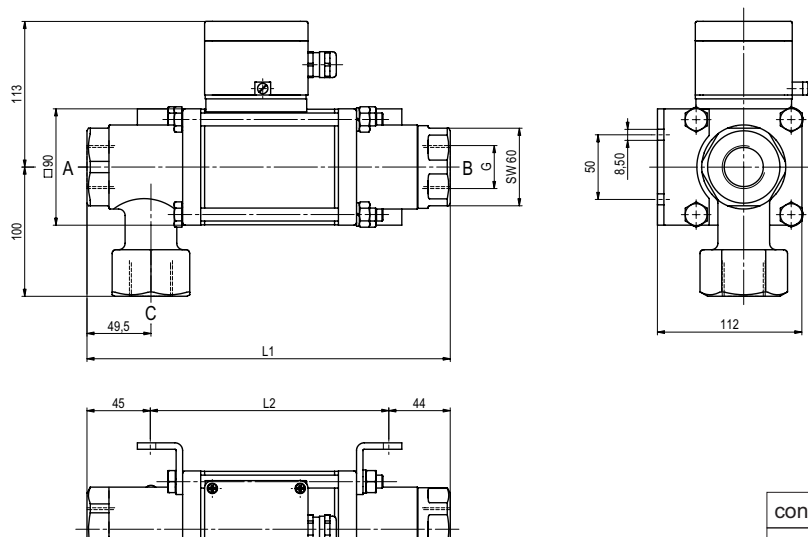

constructive length	L1	L2	L3
standard	281	192	337
with 1/2 inductive limit switches	334	245	390

flanges PN	DIN	øD	øk	ød
16	2633	115	85	14
40	2635	115	85	14

# type FK 25 DR Ex

function: **NO**  
open when not energized (A ► B)

