

coaxial valve

type MK 15 DR TÜV FK 15 DR TÜV

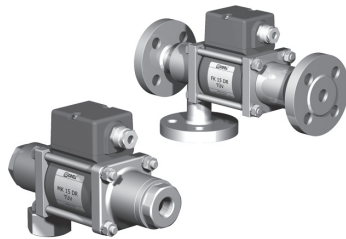

3/2 way valve direct acting
pressure range PN 0-40 bar
orifice DN 15 mm
connection thread/flange
function valve normally closed (A ► B)
 symbol **NC**

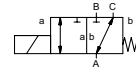

Above stated body materials refer to the valve port connections that get in contact with the media only!

design pressure balanced, with spring return, intersecting switch-over
body materials TÜV

valve seat synthetic resin on metal
seal materials FPM, PTFE

details needed

- orifice
- port
- function NC
- operating pressure
- inlet pressure at A, B or C
- flow rate
- media
- media temperature
- ambient temperature
- nominal voltage

general specifications

options

ports	MK	threads G 3/8 - G 3/4
	FK	flanges PN 40
function		NC
pressure range	bar	0-40
		A ⇒ B max.40 / B ⇒ A max.16 / A ⇒ C max.40 / C ⇒ A max.40
Kv value	m³/h	4,3
vacuum		leak rate
pressure-vacuum	P ₁ ⇔ P ₂	
back pressure	P ₂ > P ₁	see pressure range
media		liquid fuels
abrasive media		
damping	opening	
	closing	
flow direction		see pressure range
switching cycles	1/min	200
switching time	ms	opening 80 closing 80
media temperature	°C	DC: -10 to +140
		AC: -10 to +140
ambient temperature	°C	DC: -10 to +60
		AC: -10 to +60
limit switches		mechanical
manual override		
approvals	TÜV	DIN EN 264 + E DIN 32725
mounting		mounting brackets
weight	kg	MK 4,3 FK 5,9
additional equipment		

electrical specifications

options

nominal voltage	U _n	24 V	DC
	U _n	230 V 40-60 Hz	AC
actuation	DC	direct-current magnet	
	AC	direct-current magnet with separate rectifier	
insulation rating	H	180°C	
protection	IP65		
energized duty rating	ED	100%	
connection	M16x1,5	terminal box	
optional additional equipment			
current consumption	N-coil		
	H-coil	24 V	DC 2,30 A
		230 V 40-60 Hz	AC 0,24 A
explosion proof			
limit switches		mechanical	single pole double throw-SPDT

The valves' technical design is based on media and application requirements. This can lead to deviations from the general specifications shown on the data sheet with regards to the design, sealing materials and characteristics.

If order or application specifications are incomplete or imprecise there exists a risk of an incorrect technical design of the valve for the required application. As a consequence, the physical and / or chemical properties of the materials or seals used, may not be suitable for the intended application.

specifications not highlighted are standard
 specifications highlighted in grey are optional

type MK 15 DR TÜV

function: **NC**
closed when not energized (A ► B)

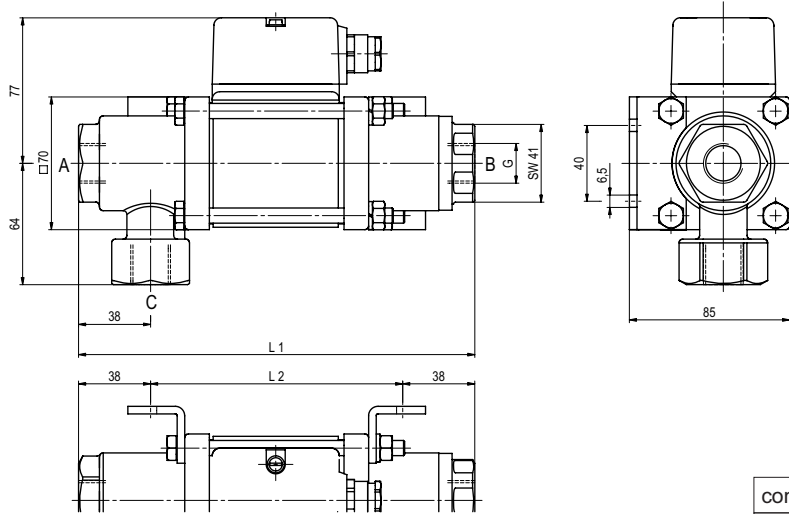

constructive length	L1	L2	L3
standard	209	133	265
with mechanical limit switches	229	153	285

type FK 15 DR TÜV

function: **NC**
closed when not energized (A ► B)

