

coaxial valve

type MK 15 DR FK 15 DR

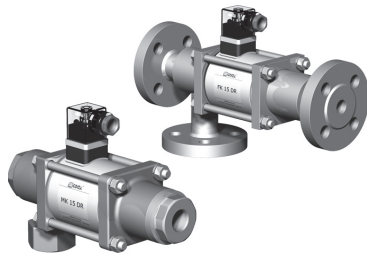

3/2 way valve **direct acting**
pressure range PN 0-40 bar
orifice DN 15 mm
connection thread/flange
function valve normally closed (A ► B) symbol **NC**
 valve normally open (A ► B) symbol **NO**

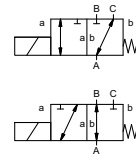

△ Above stated body materials refer to the valve port connections that get in contact with the media only!

design pressure balanced, with spring return, intersecting switch-over
body materials ① brass ② steel, galvanized
 ③ brass, nickel plated ⑤ without non-ferr. metals
 ④ steel, nickel plated ⑥ stainless steel
valve seat synthetic resin on metal
seal materials NBR PTFE, FPM, CR, EPDM

details needed

- orifice
- port
- function NC/NO
- operating pressure
- inlet pressure at A, B or C
- flow rate
- media
- media temperature
- ambient temperature
- nominal voltage

	general specifications		options
ports	MK	threads G 3/8 - G 3/4	special threads
	FK	flanges PN 16/40	special flanges
function		NC	NO
pressure range	bar	0-16/0-40	
		A ⇒ B max.40 / B ⇒ A max.16 / A ⇒ C max.40 / C ⇒ A max.40	
Kv value	m ³ /h	4,3	
vacuum	leak rate		< 10 ⁻⁶ mbar·l/s ⁻¹
pressure-vacuum	P ₁ ⇔ P ₂		upon request
back pressure	P ₂ > P ₁	see pressure range	
media		gaseous - liquid - highly viscous - gelatinous - contaminated	
abrasive media			upon request
damping	opening		
	closing		
flow direction		see pressure range	
switching cycles	1/min	200	
switching time	ms	opening 80 closing 80	
media temperature	°C	DC: -20 to +80	-40 to +160
		AC: -20 to +80	-40 to +160
ambient temperature	°C	DC: -20 to +80	
		AC: -20 to +80	
limit switches			inductive/mech. (depend. on temperature)
manual override			available
approvals			LR/GL/WAZ
mounting			mounting brackets
weight	kg	MK 4,3 FK 5,9	
additional equipment			upon request

⚠ The valves' technical design is based on media and application requirements. This can lead to deviations from the general specifications shown on the data sheet with regards to the design, sealing materials and characteristics.

⚠ If order or application specifications are incomplete or imprecise there exists a risk of an incorrect technical design of the valve for the required application. As a consequence, the physical and / or chemical properties of the materials or seals used, may not be suitable for the intended application.

	electrical specifications		options
nominal voltage	U _n	24 V DC	special voltage upon request
	U _n	230 V 40-60 Hz AC	special voltage upon request
actuation	DC	direct-current magnet	
	AC	direct-current magnet with integrated rectifier	above 100°C with separate rectifier
insulation rating	H	180°C	
protection	IP65		
energized duty rating	ED	100%	
connection		plug acc. DIN EN 175301-803 form A, 4 positions x 90° / wire diameter 6-8 mm	terminal box M16x1,5
optional	M12x1	connector acc. DESINA	connector acc. VDMA
additional equipment		illuminated plug with varistor	
current consumption	N-coil	24 V DC 1,60 A	
		230 V 40-60 Hz AC 0,15 A	
	H-coil		24 V DC 2,30 A
			230 V 40-60 Hz AC 0,24 A
explosion proof			
limit switches		inductive (I)	normally open-PNP
		inductive (B)	normally open-PNP
		mechanical	single pole double throw-SPDT

■ specifications not highlighted are standard
 ■ specifications highlighted in grey are optional

type MK 15 DR

function: **NC**
closed when not energized (A ► B)

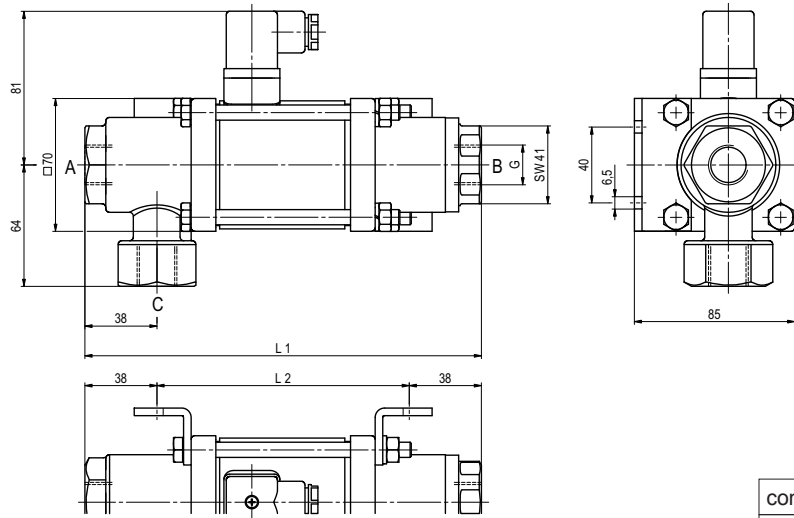

constructive length	L1	L2	L3
standard	209	133	265
with 1/2 inductive limit switches	249	173	305
with manual emergency (Hd)/ Hd and 1/2 ind. limit switches	249	173	305
with mechanical limit switches	249	173	305

flanges PN	DIN	øD	øk	ød
16	2633	95	65	14
40	2635	95	65	14

type FK 15 DR

function: **NO**
open when not energized (A ► B)

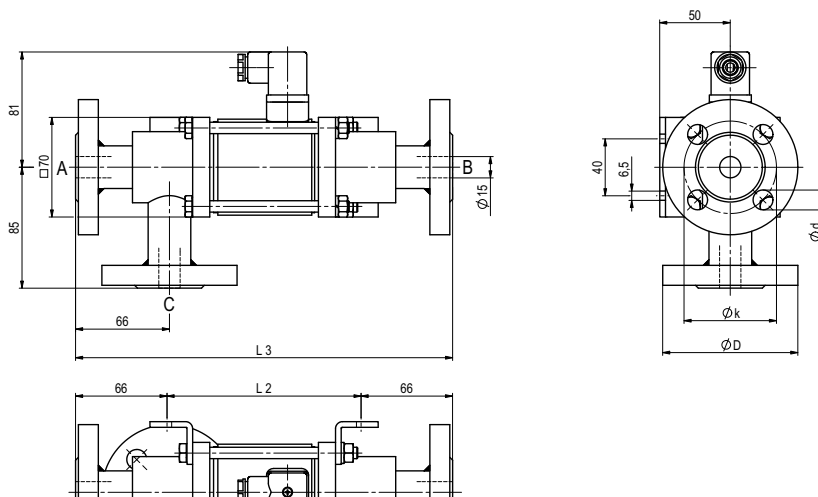

The application-specific layout relating to temperature, pressure conditions, switching behavior, media and its consistency may restrict the range of use or necessitate relevant modifications to materials used and seal arrangements.

Rights reserved to make technical alterations • Not responsible for printing errors • Detailed drawings can be obtained upon request