

pressure reduction valve

type **HPI-1 32**
HPI-2 32

3-HPI-1 32

3-HPI-2 32

valve type with pilot valve



control valve manual externally controlled
pressure range PN 0-100 bar
orifice DN 32 mm
connection thread
function manual stepless pressure regulation

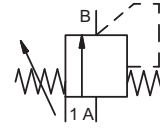

Above stated body materials refer to the valve port connections that get in contact with the media only!

design externally controlled with spring return

body materials ① brass ④
 ② ⑤
 ③ ⑥

valve seat metal on metal

seal materials PU, NBR **FPM**

details needed for main valve

- orifice
- port
- pressure regulating range
- flow rate
- media
- media temperature
- ambient temperature

details needed for pneumatic actuation

- nominal voltage
- type of protection
- actuation pressure range min/max

general specifications

options

ports	HPI-1 G 1 1/2	
	HPI-2 G 1 1/2	
function	stepless regulation	
pressure regulation range	bar HPI-1 5-40	HPI-2 5-100
Kv value	m³/h max. 24,3	
media	gaseous - liquid - highly viscous - contaminated	
abrasive media	A ⇌ B as marked	
flow direction	ms HPI-1 < 200	
operating time	°C 0 to +60	
media temperature	°C 0 to +50	
ambient temperature		
approvals		
mounting	mounting bracket	
weight	kg HPI-1 15,1	HPI-2 16,2
additional equipment		

electrical specifications

options

nominal voltage	U _n 24 V DC	special voltage upon request
	U _n 230 V 50 Hz AC	special voltage upon request
power consumption	DC 4,8 W	2,5 W
	AC pick up 11,0 VA holding 8,5 VA	
protection	IP 65 (P54) acc. DIN 40 050	
energized duty rating	ED 100%	
connection	plug acc. DIN EN 175301-803 form B	
additional equipment	illuminated plug with varistor	
optional	M12x1 connector acc. DESINA	connector acc. VDMA
coil	3 positions x 90° / wire diameter 6-8 mm	
max. temperature	media 60°C	
	ambient 50°C	
explosion proof	EEx m II T5 nominal voltage U _n	direct current 24 V 3,25 W
	power consumption	alternating current 230 V 50 Hz 2,90 W

pneumatic specifications

options

actuation pressure range	bar see actuation pressure-diagram
air consumption	DIN ISO 8573-1 grade of compressed air quality 5/4/3
control	preferably 3/2-way pilot valve during low pressure circulation mode
actuator ports	1 G 1/8

The valves' technical design is based on media and application requirements. This can lead to deviations from the general specifications shown on the data sheet with regards to the design, sealing materials and characteristics.

If order or application specifications are incomplete or imprecise there exists a risk of an incorrect technical design of the valve for the required application. As a consequence, the physical and / or chemical properties of the materials or seals used, may not be suitable for the intended application.

■ specifications not highlighted are standard
 ■ specifications highlighted in grey are optional

type HPI-1 32

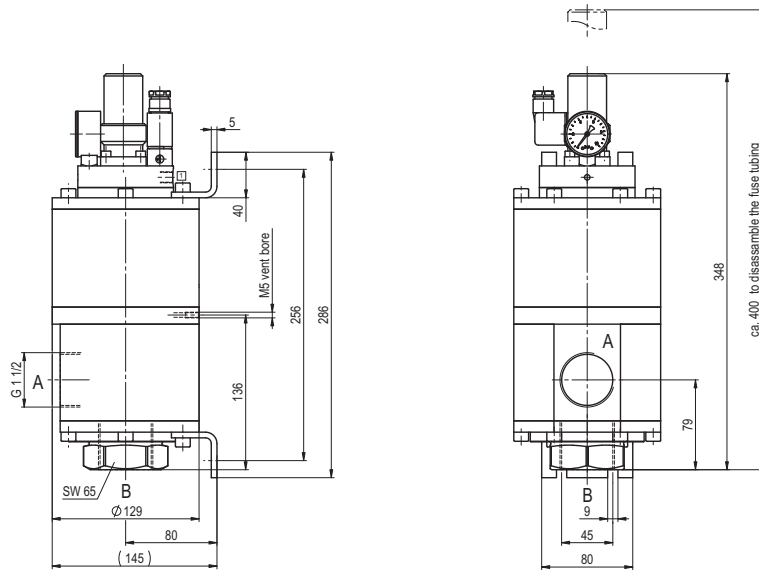

type HPI-2 32

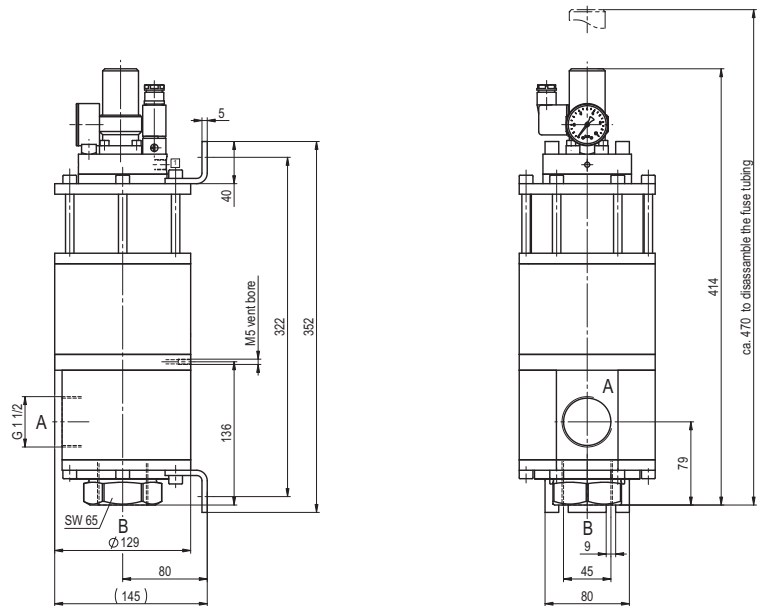

actuation pressure-diagram

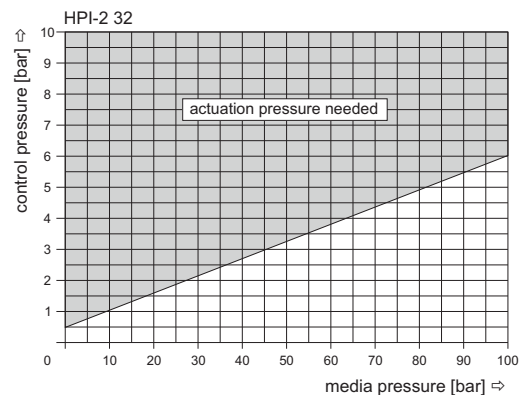
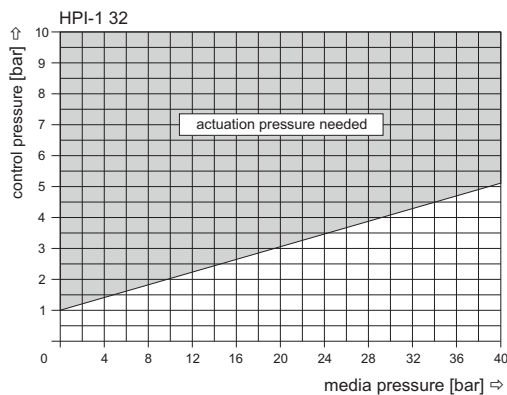

The application-specific layout relating to temperature, pressure conditions, switching behavior, media and its consistency may restrict the range of use or necessitate relevant modifications to materials used and seal arrangements.

Rights reserved to make technical alterations • Not responsible for printing errors • Detailed drawings can be obtained upon request