

pressure limitation valve

type HPB-H 15

3-HPB-H 15

valve type with pilot valve



control valve manuel
pressure range PN 5-120 bar
orifice DN 15 mm
connection thread
function manual stepless pressure regulation

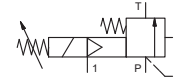

 Above stated body materials refer to the valve port connections that get in contact with the media only!

design externally controlled with spring return
body materials ① ④
 ② steel, galvanized ⑤
 ③ ⑥
valve seat metal on metal
seal materials FPM, PTFE

details needed for main valve

- orifice
- port
- pressure regulating range
- flow rate
- media
- media temperature
- ambient temperature

details needed for pneumatic actuation

- nominal voltage
- type of protection
- actuation pressure range min/max

general specifications

ports	HPB	threads G 1	options	SAE connection DIN ISO 6162
function		stepless regulation		
pressure regulation range	bar	5-120		
Kv value	m ³ /h	6,0		
media		liquid - highly viscous - contaminated		
abrasive media				
flow direction	P ⇌ T	as marked		
operating time	ms	< 900		
media temperature	°C	0 to +60		
ambient temperature	°C	0 to +50		
approvals				
mounting		mounting holes		
weight	kg	2,6		
additional equipment				security valve

electrical specifications

nominal voltage	U _n	24 V DC	options	special voltage upon request
	U _n	230 V 50 Hz AC		special voltage upon request
power consumption	DC	4,8 W		2,5 W
	AC	pick up 11,0 VA holding 8,5 VA		
protection	IP 65 (P54)	acc. DIN 40 050		
energized duty rating	ED	100%		
connection		plug acc. DIN EN 175301-803 form B		
additional equipment		illuminated plug with varistor		
optional	M12x1	connector acc. DESINA		connector acc. VDMA
coil		3 positions x 90° / wire diameter 6-8 mm		
max. temperature	media	60°C		
	ambient	50°C		
explosion proof	EEx m II T5	nominal voltage U _n	direct current	24 V 3,25 W
		power consumption	alternating current	230 V 50 Hz 2,90 W

pneumatic specifications

actuation pressure range	bar	see actuation pressure-diagram	options	
air consumption		DIN ISO 8573-1 grade of compressed air quality 5/4/3		
control		preferably 3/2-way pilot valve during low pressure circulation mode		
actuator ports	1	G 1/8		

 The valves' technical design is based on media and application requirements. This can lead to deviations from the general specifications shown on the data sheet with regards to the design, sealing materials and characteristics.

 If order or application specifications are incomplete or imprecise there exists a risk of an incorrect technical design of the valve for the required application. As a consequence, the physical and / or chemical properties of the materials or seals used, may not be suitable for the intended application.

■ specifications not highlighted are standard
 ■ specifications highlighted in grey are optional

type 3-HPB-H 15

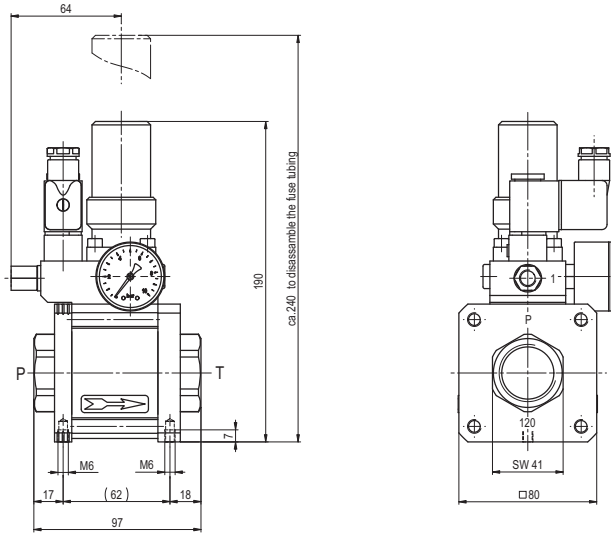

type HPB-H 15

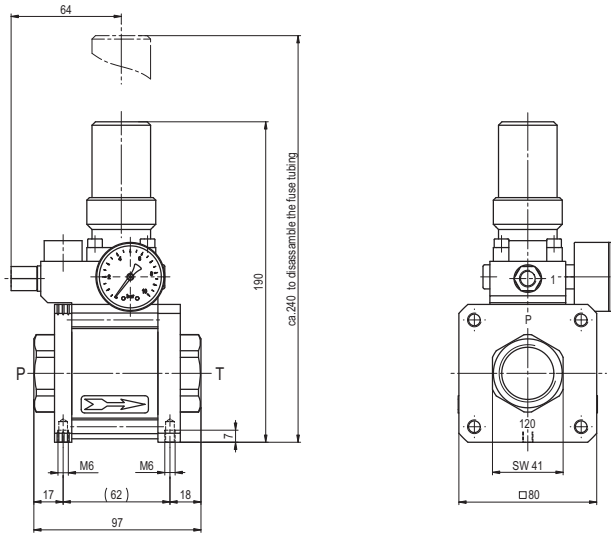

actuation pressure-diagram

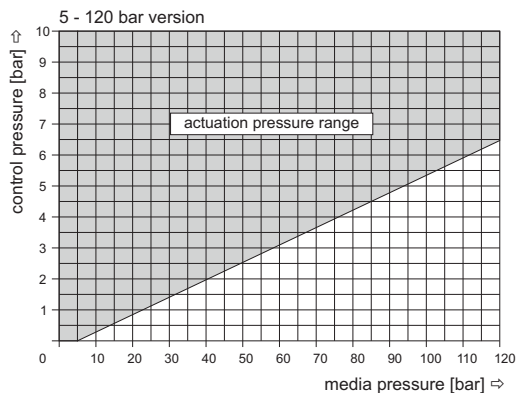

pressureless circulation mode

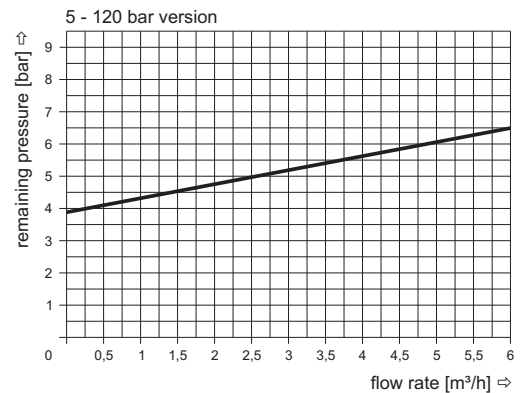

Sound creation during low pressure circulation mode and flow $Q=6 \text{ m}^3/\text{h}$: ca. 70 dbA

The application-specific layout relating to temperature, pressure conditions, switching behavior, media and its consistency may restrict the range of use or necessitate relevant modifications to materials used and seal arrangements.

Rights reserved to make technical alterations • Not responsible for printing errors • Detailed drawings can be obtained upon request