

# coaxial valve

## type FCF 100

### 5-FCF 100

valve type with pilot valve

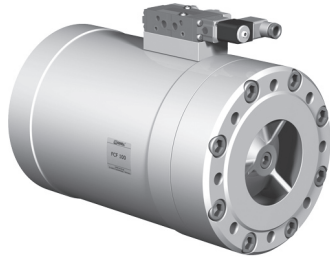

**2/2 way valve** externally controlled  
**pressure range** PN 0-40 bar  
**orifice** DN 100 mm  
**connection** flange  
**function** valve normally closed symbol **NC**  
 valve normally open symbol **NO**

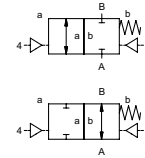

**△** Above stated body materials refer to the valve port connections that get in contact with the media only!

**design** pressure balanced, with spring return

**body materials** ① aluminium ②  
 ③ ⑤  
 ④ ⑥

**valve seat** synthetic resin on metal  
**seal materials** NBR, PU PTFE, FPM, PE

**details needed for main valve**

- orifice
- port
- function NC/NO
- operating pressure
- flow rate
- media
- media temperature
- ambient temperature
- type of actuation

**details needed for pneumatic actuation**

- nominal voltage
- type of protection
- actuation pressure range min/max
- pilot valve type

**details needed for hydraulic actuation**

- actuation pressure range min/max
- hydraulic control valve function

**⚠** The valves' technical design is based on media and application requirements. This can lead to deviations from the general specifications shown on the data sheet with regards to the design, sealing materials and characteristics.

**⚠** If order or application specifications are incomplete or imprecise there exists a risk of an incorrect technical design of the valve for the required application. As a consequence, the physical and / or chemical properties of the materials or seals used, may not be suitable for the intended application.

■ specifications not highlighted are standard  
 ■ specifications highlighted in grey are optional

**general specifications**

ports	FCF	flanges PN 16/40
function	NC	NO
pressure range	bar	0-16/0-40
Kv value	m³/h	215,0
vacuum	leak rate	< 10 <sup>-4</sup> mbar·l·s <sup>-1</sup>
pressure-vacuum	P <sub>1</sub> ⇔ P <sub>2</sub>	pressure side max. 40 bar vacuum side leak rate upon request
back pressure	P <sub>2</sub> > P <sub>1</sub>	available (max. 16 bar)
media	emulsions - oils - neutral gases	other medias upon request
abrasive media		
damping	opening	
	closing	by throttles on pilot valve
flow direction	A ⇔ B	as marked bi-directional upon request (max. 16 bar)
switching cycles	1/min	40
switching time	ms	opening 450-3000 closing 300-3000
media temperature	°C	direct mounted pilot valve 60 >60°C upon request
ambient temperature	°C	direct mounted pilot valve 50 >50°C upon request
flush ports		
leak ports		
limit switches		inductive upon request
manual override	via pilot valve	
approvals		upon request
mounting		
weight	kg	FCF 34,0
additional equipment		sensor / manometer connection G 1/4

**electrical specifications**

nominal voltage	U <sub>n</sub>	DC 24V	special voltage upon request
	U <sub>n</sub>	AC 230V 50 Hz	special voltage upon request
power consumption	DC	4,8 W	
	AC	pick up 11,0 VA holding 8,5 VA	
protection	IP 65 (P54)	acc. DIN 40 050	
energized duty rating	ED	100%	
connection		plug acc. DIN EN 175301-803 form B, 4 positions x 90° / wire diameter 6-8 mm	
additional equipment		illuminated plug with varistor	
optional	M12x1	connector acc. DESINA	connector acc. VDMA
max. temperature	media	60°C	
	ambient	50°C	
explosion proof	EEx m II T5	nominal voltage U <sub>n</sub>	direct current 24 V 3,25 W
		power consumption	alternating current 230 V 50 Hz 2,90 W

**pneumatic specifications**

actuation pressure range	bar	4-10	3-10 upon request
air consumption	cm³/stroke	250	
cycle speed		main valve speed variable by throttles on pilot valve	
control		preferably 5/2-way pilot valve	
pilot valve interface	NAMUR VDI / VDE 3845		ISO 1 DIN 5599/1
actuator ports	2/4	G 1/4	G 3/8

**hydraulic specifications**

actuation pressure range	bar	30-60
by media		
control		preferably 4/2-way control valve
actuator ports	X/Y	G 1/4 NPT 1/4

# type FCF 100

function: **NC**  
closed when not energized

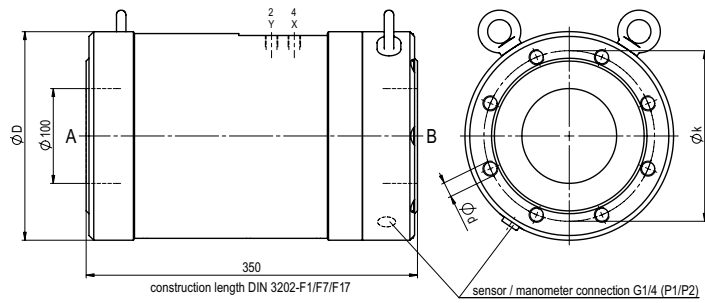

flanges PN	DIN	øD	øk	ød
16	2633	220	180	M16
40	2635	235	190	M20

# type FCF 100

function: **NO**  
open when not energized

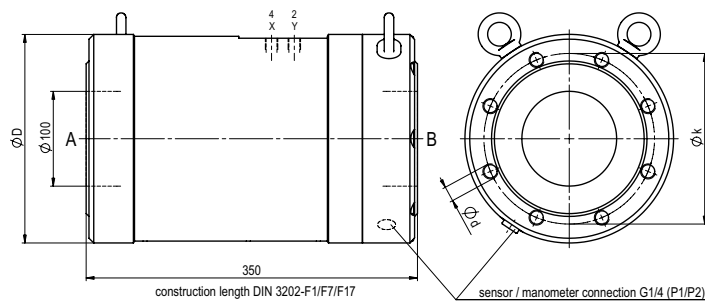

### pneumatic actuation (separately)

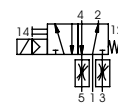

5/2-way-pilot valve  
flow rate 700 l/min  
pressure range 3-10 bar G 1/8

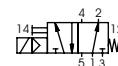

5/2-way-pilot valve ISO 1  
flow rate 700 l/min  
pressure range 3-10 bar G 1/4