

coaxial valve

type CFM 08

3-CFM 08

valve type with pilot valve



2/2 way valve externally controlled
pressure range PN 0-40 bar
orifice DN 8 mm
connection thread
function valve normally closed symbol **NC**
 valve normally open symbol **NO**

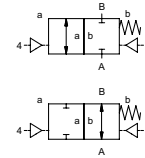

△ Above stated body materials refer to the valve port connections that get in contact with the media only!

design pressure balanced, with spring return
body materials ① brass ②
 ③ ⑤
 ④ ⑥

valve seat synthetic resin on metal
seal materials NBR, FPM, PE **PU, PTFE**

details needed for main valve

- orifice
- port
- function NC/NO
- operating pressure
- flow rate
- media
- media temperature
- ambient temperature
- type of actuation

details needed for pneumatic actuation

- nominal voltage
- type of protection
- actuation pressure range min/max
- low wattage coil, actuation pressure range 4-7 bar
- pilot valve type

⚠ The valves' technical design is based on media and application requirements. This can lead to deviations from the general specifications shown on the data sheet with regards to the design, sealing materials and characteristics.

⚠ If order or application specifications are incomplete or imprecise there exists a risk of an incorrect technical design of the valve for the required application. As a consequence, the physical and / or chemical properties of the materials or seals used, may not be suitable for the intended application.

■ specifications not highlighted are standard
 ■ specifications highlighted in grey are optional

general specifications

ports	CFM	threads G 3/8
function	NC	NO
pressure range	bar	0-40
Kv value	m ³ /h	1,6
vacuum	leak rate	< 10 ⁻⁶ mbar·l/s ⁻¹
pressure-vacuum	P ₁ ↔ P ₂	
back pressure	P ₂ > P ₁	available (max. 16 bar)
media	emulsions - oils - neutral gases	other medias upon request
abrasive media		
damping	opening	
	closing	
flow direction	A ↔ B	as marked
switching cycles	1/min	400
switching time	ms	opening 70 closing 80
media temperature	°C	direct mounted pilot valve 60 >60°C upon request
ambient temperature	°C	direct mounted pilot valve 50 >50°C upon request
flush ports		
leak ports		
limit switches		reed, temperature range max 70°C
manual override	via pilot valve	
approvals		
mounting		mounting brackets
weight	kg	0,3
additional equipment		

electrical specifications

nominal voltage	U _n	DC 24V	special voltage upon request
	U _n	AC 230V 40-60 Hz	special voltage upon request
power consumption	DC	4,8 W	2,5 W
	AC	pick up 11,0 VA holding 8,5 VA	
protection	IP 65 (P54)	acc. DIN 40 050	
energized duty rating	ED	100%	
connection		plug acc. DIN EN 175301-803 form B, 4 positions x 90° / wire diameter 6-8 mm	
additional equipment		illuminated plug with varistor	
optional	M12x1	connector acc. DESINA	connector acc. VDMA
max. temperature	media	60°C	
	ambient	50°C	
explosion proof	EEx m II T5	nominal voltage U _n	direct current 24 V 3,25 W
		power consumption	alternating current 230 V 50 Hz 2,90 W

pneumatic specifications

actuation pressure range	bar	4-10	3-10 upon request
air consumption	cm ³ /stroke	1,2	
cycle speed			by 3/2-way pilot valve
control			
pilot valve interface	co-ax		CNOMO upon request
actuator ports	2/4	G 1/8	

hydraulic specifications

actuation pressure range		
control		
actuator ports		

