

coaxial valve

type **MK 15 DR** **FK 15 DR**

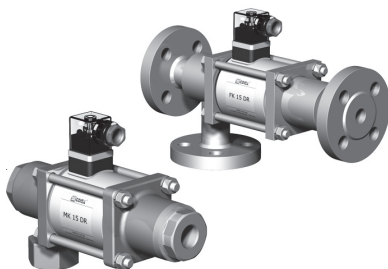

3/2 way valve **direct acting**
pressure range PN 0-40 bar
orifice DN 15 mm
connection thread/flange
function valve normally closed (A ► B) symbol **NC**
 valve normally open (A ► B) symbol **NO**

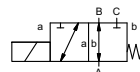
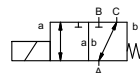

⚠ Above stated body materials refer to the valve port connections that get in contact with the media only!

design pressure balanced, with spring return, intersecting switch-over
body materials ① brass ② steel, galvanized
 ③ brass, nickel plated ⑤ without non-ferr. metals
 ④ steel, nickel plated ⑥ stainless steel
valve seat synthetic resin on metal
seal materials NBR PTFE, FPM, CR, EPDM

details needed

- orifice
- port
- function NC/NO
- operating pressure
- inlet pressure at A, B or C
- flow rate
- media
- media temperature
- ambient temperature
- nominal voltage

general specifications		options
ports	MK threads G 3/8 - G 3/4 FK flanges PN 16/40	special threads special flanges
function	NC	NO
pressure range	bar 0-16/0-40 A ⇒ B max.40 / B ⇒ A max.16 / A ⇒ C max.40 / C ⇒ A max.40	
Kv value	m³/h 4,3	
vacuum	leak rate	< 10 ⁻⁶ mbar·l·s ⁻¹
pressure-vacuum	P ₁ ⇄ P ₂	upon request
back pressure	P ₂ > P ₁ see pressure range	
media	gaseous - liquid - highly viscous - gelatinous - contaminated	
abrasive media		upon request
damping	opening closing	
flow direction	see pressure range	
switching cycles	1/min 200	
switching time	ms opening 80 closing 80	
media temperature	°C DC: -20 to +80 AC: -20 to +80	-40 to +160 -40 to +160
ambient temperature	°C DC: -20 to +80 AC: -20 to +80	
limit switches		inductive/mech. (depend. on temperature)
manual override		available
approvals		LR/GL/WAZ
mounting		mounting brackets
weight	kg MK 4,3 FK 5,9	
additional equipment		upon request

⚠ The valves' technical design is based on media and application requirements. This can lead to deviations from the general specifications shown on the data sheet with regards to the design, sealing materials and characteristics.

⚠ If order or application specifications are incomplete or imprecise there exists a risk of an incorrect technical design of the valve for the required application. As a consequence, the physical and / or chemical properties of the materials or seals used, may not be suitable for the intended application.

electrical specifications		options
nominal voltage	U _n 24 V DC U _n 230 V 40-60 Hz AC	special voltage upon request special voltage upon request
actuation	DC direct-current magnet AC direct-current magnet with integrated rectifier	above 100°C with separate rectifier
insulation rating	H 180°C	
protection	IP65	
energized duty rating	ED 100%	
connection	plug acc. DIN EN 175301-803 form A, 4 positions x 90° / wire diameter 6-8 mm	terminal box M16x1,5
optional additional equipment	M12x1 connector acc. DESINA illuminated plug with varistor	connector acc. VDMA
current consumption	N-coil 24 V DC 1,60 A 230 V 40-60 Hz AC 0,15 A	
H-coil		24 V DC 2,30 A 230 V 40-60 Hz AC 0,24 A
explosion proof		
limit switches	inductive (I) inductive (B) mechanical	normally open-PNP normally open-PNP single pole double throw-SPDT

■ specifications not highlighted are standard
 specifications highlighted in grey are optional

type MK 15 DR

function: **NC**
closed when not energized (A ► B)

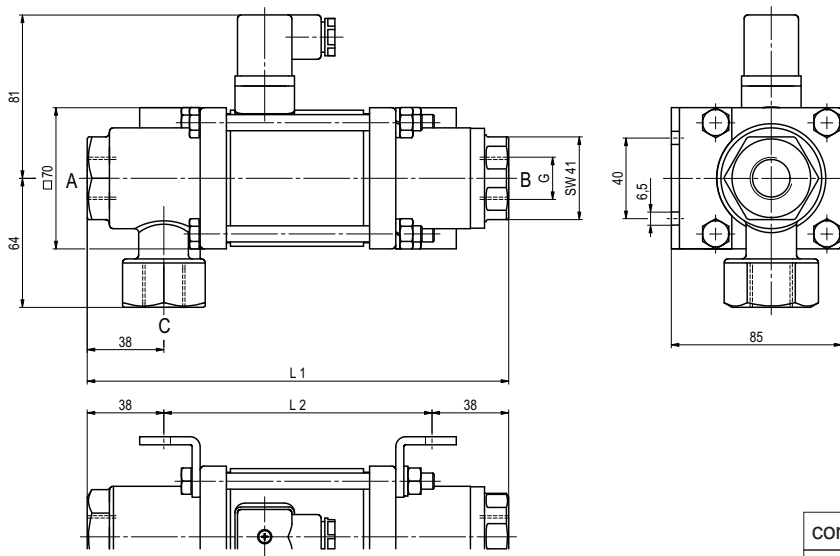

constructive length	L1	L2	L3
standard	209	133	265
with 1/2 inductive limit switches	249	173	305
with manual emergency (Hd)/ Hd and 1/2 ind. limit switches	249	173	305
with mechanical limit switches	249	173	305

flanges PN	DIN	øD	øk	ød
16	2633	95	65	14
40	2635	95	65	14

type FK 15 DR

function: **NO**
open when not energized (A ► B)

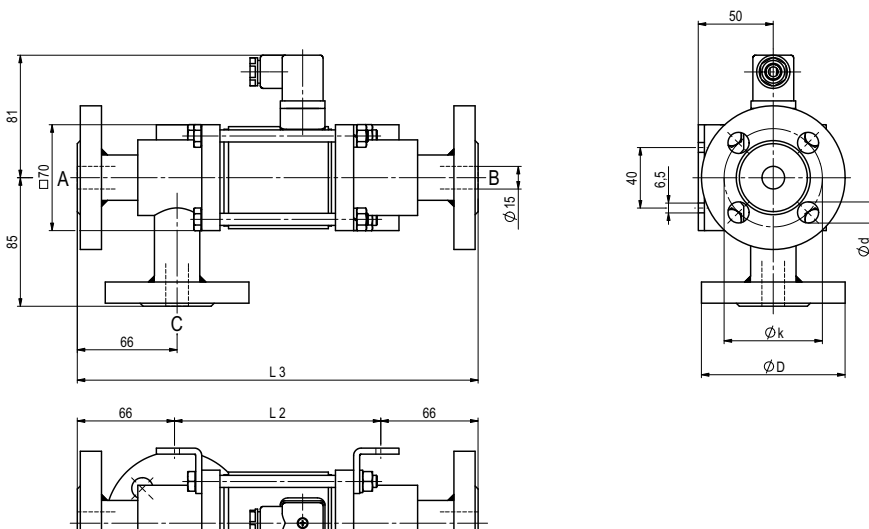

The application-specific layout relating to temperature, pressure conditions, switching behavior, media and its consistency may restrict the range of use or necessitate relevant modifications to materials used and seal arrangements.

Rights reserved to make technical alterations • Not responsible for printing errors • Detailed drawings can be obtained upon request