

coaxial valve

type **MK 15**
FK 15

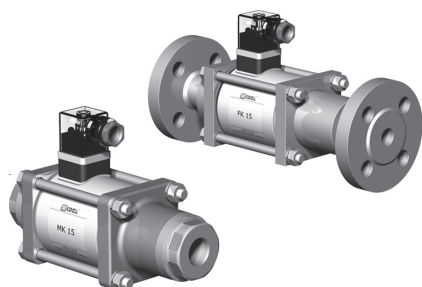

2/2 way valve **direct acting**
pressure range PN 0-100 bar
orifice DN 15 mm
connection thread/flange
function valve normally closed symbol **NC**
valve normally open symbol **NO**

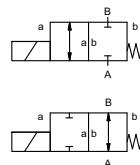

△ Above stated body materials refer to the valve port connections that get in contact with the media only!

design pressure balanced, with spring return
body materials ① brass ② steel, galvanized
③ brass, nickel plated ⑤ without non-ferr. metals
④ steel, nickel plated ⑥ stainless steel
valve seat synthetic resin on metal
seal materials NBR PTFE, FPM, CR, EPDM

details needed

- orifice
- port
- function NC/NO
- operating pressure
- flow rate
- media
- media temperature
- ambient temperature
- nominal voltage

general specifications		options
ports	MK threads G 3/8 - G 3/4 FK flanges PN 16/40/100	special threads special flanges
function	NC	NO
pressure range	bar 0-16/0-40/0-64/0-100	> 100 bar upon request
Kv value	m³/h 4,8	
vacuum	leak rate	< 10 ⁻⁶ mbar•l•s ⁻¹
pressure-vacuum	P ₁ ⇔ P ₂	upon request
back pressure	P ₂ > P ₁	available (max. 16 bar)
media	gaseous - liquid - highly viscous - gelatinous - contaminated	
abrasive media		upon request
damping	opening	
	closing	available
flow direction	A ⇔ B as marked	bi-directional (max. 16 bar)
switching cycles	1/min 200	
switching time	ms opening 80 closing 80	
media temperature	°C DC: -20 to +100 AC: -20 to +100	-40 to +160 -40 to +160
ambient temperature	°C DC: -20 to +80 AC: -20 to +80	
limit switches		inductive/mech. (depend. on temperature)
manual override		available
approvals		LR/GL/WAZ
mounting		mounting brackets
weight	kg MK 3,8 FK 5,0	
additional equipment		upon request

△ The valves' technical design is based on media and application requirements. This can lead to deviations from the general specifications shown on the data sheet with regards to the design, sealing materials and characteristics.

△ If order or application specifications are incomplete or imprecise there exists a risk of an incorrect technical design of the valve for the required application. As a consequence, the physical and / or chemical properties of the materials or seals used, may not be suitable for the intended application.

electrical specifications		options
nominal voltage	U _n 24 V DC U _n 230 V 40-60 Hz AC	special voltage upon request special voltage upon request
actuation	DC direct-current magnet AC direct-current magnet with integrated rectifier	above 100°C with separate rectifier
insulation rating	H 180°C	
protection	IP65	
energized duty rating	ED 100%	
connection	plug acc. DIN EN 175301-803 form A, 4 positions x 90° / wire diameter 6-8 mm	terminal box M16x1,5
optional additional equipment	M12x1 connector acc. DESINA illuminated plug with varistor	connector acc. VDMA
current consumption	N-coil 24 V DC 1,60 A 230 V 40-60 Hz AC 0,15 A	
H-coil		24 V DC 2,30 A 230 V 40-60 Hz AC 0,24 A
explosion proof		
limit switches	inductive (I) induktiv (B) mechanical	normally open-PNP normally open-PNP single pole double throw-SPDT

■ specifications not highlighted are standard
■ specifications highlighted in grey are optional

type MK 15

function: **NC**
closed when not energized

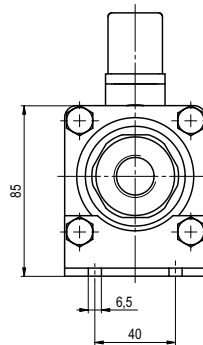
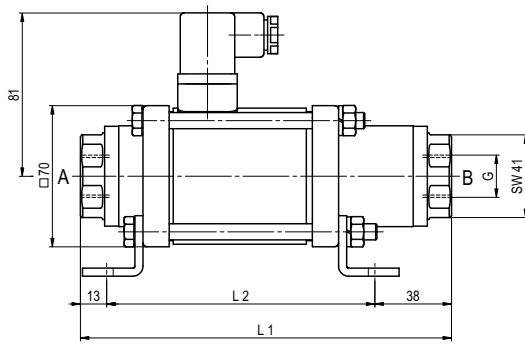

constructive length	L ₁	L ₂	L ₃
standard	184	133	241
with 1/2 inductive limit switches	224	173	281
with manual emergency (Hd)/ Hd and 1/2 ind. limit switches	224	173	281
with mechanical limit switches	224	173	281

flanges PN	DIN	øD	øk	ød
16	2633	95	65	14
40	2635	95	65	14
100	2637	105	75	14

type FK 15

function: **NO**
open when not energized

